

BANK NOTE PAPER MILL INDIA PRIVATE LIMITED,
CIN: U21090KA2010PTC055475
CORPORATE OFFICE, MYSORE
bhoodhar@bnpmindia.com
T-0821-2401-174

ENQUIRY No: BNPM/ENQ/ Hydraulic cylinder /327/2017-18

Start Date: 13.12.2017

End date:20.12.2017

1. Scope of work:

Supply of "Hydraulic Cylinders".

2. Terms & Conditions:

S. No.	Particulars	Quantity
1	Specification	(As per attached drawing)
1.	Payment Terms	100% After receipt and acceptance of goods by the consignee at destination and on production of all required documents by the supplier. <u>Warranty certificate (if applicable) and NEFT/RTGS details shall be furnished along with invoice.</u>
2.	Price	Price should be inclusive of all taxes & duties.
3.	Freight	Shall be included in quoted price
4.	Packing & Forwarding	Shall be included in quoted price
5.	Delivery Terms	DAP, Bank Note Paper Mill India Private Limited, Mysore
6.	Warranty Period (Please specify)
7.	Warranty Certificate	Not Applicable/Applicable
8.	Delivery Period(Please specify)
9.	Quotation through	By mail
10	Material to be delivered at	Engineering Stores Bank Note Paper Mill India Private Limited Note Mudran Nagar Mysore 570 003



Price Bid Format

S. No.	Description	Qty in NOS (A)	Unit rate (B)	GST@..... (C)	Value in INR D=(B+C)	Total Value in INR E=(D*A)
1	Hydraulic cylinder for Rewinder ride roll (As per attached drawing)	1				
2	Hydraulic cylinder for Rewinder core guide. (As per attached drawing)	1				
3	Hydraulic cylinder for Rewinder roll ejector. (As per attached drawing)	1				
4	Hydraulic cylinder for Rewinder cross cutter (As per attached drawing)	1				
Grand Total (1+2+3+4)						
Grand Total in word:						

We hereby confirm that

1. We accept all terms & conditions mentioned in the enquiry.
2. Price quoted is inclusive of all taxes, duties, P&F, freight etc. on DAP, BNPM, Mysore basis.

Signature of bidder:.....

Name of the Firm:.....

Seal of the firm:



SL NO: 01

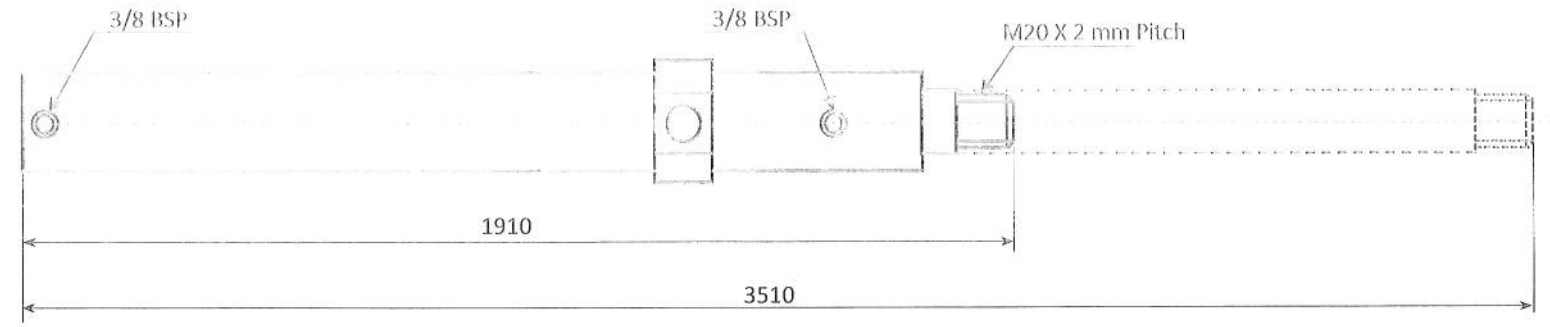
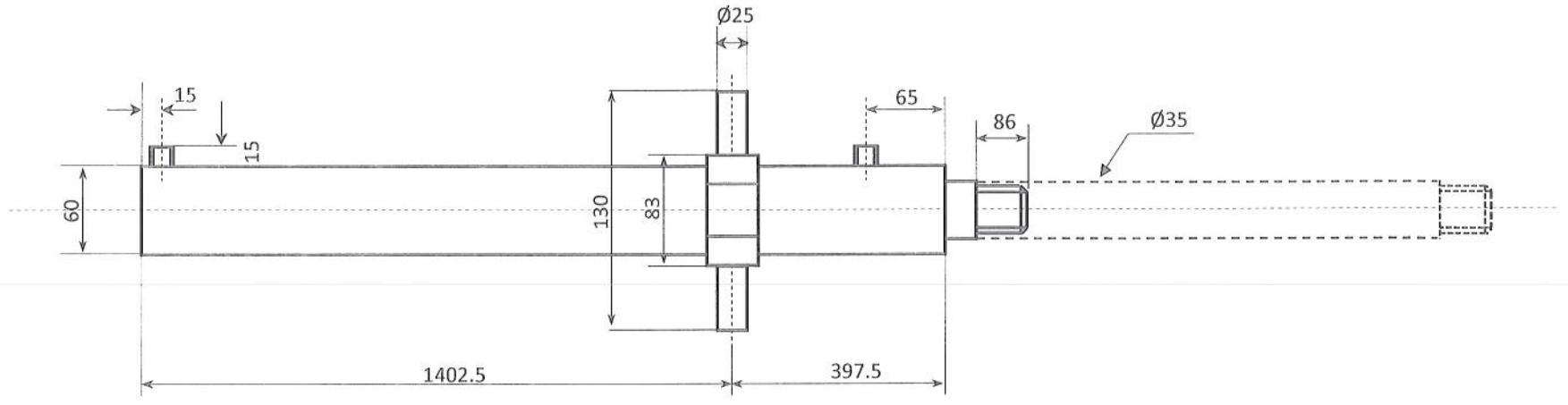

REWINDER RIDER ROLL HYD CYLINDER



AB

SL NO: 02

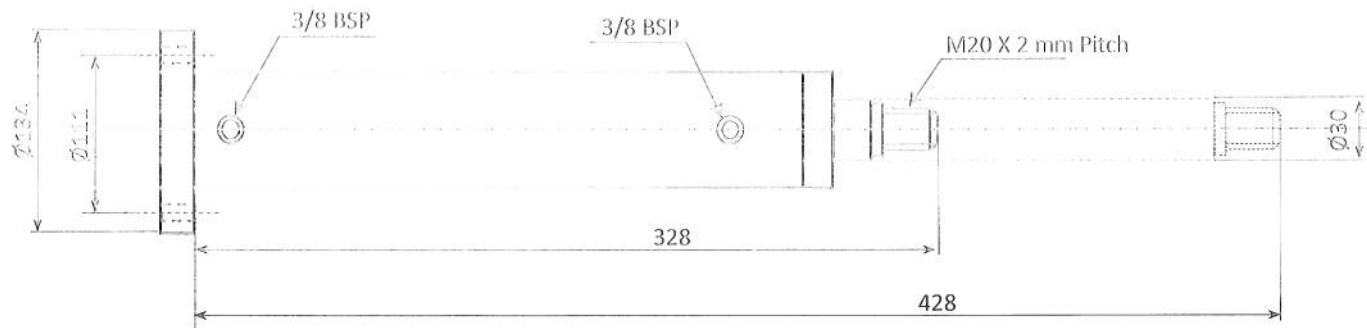
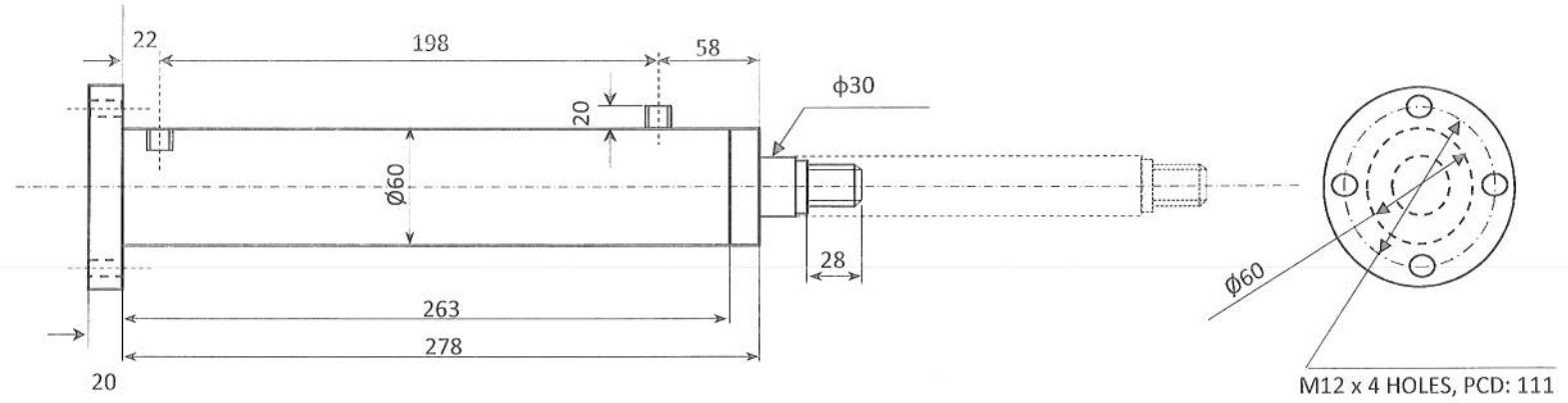

REWINDER CORE GUIDE HYDRAULIC CYLINDER



SL NO : 03

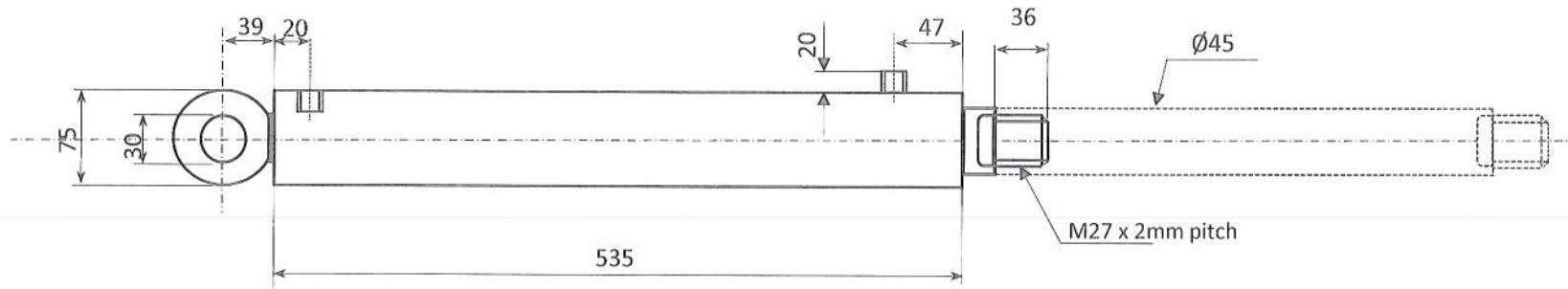

PISTON ROD END CLEVIS

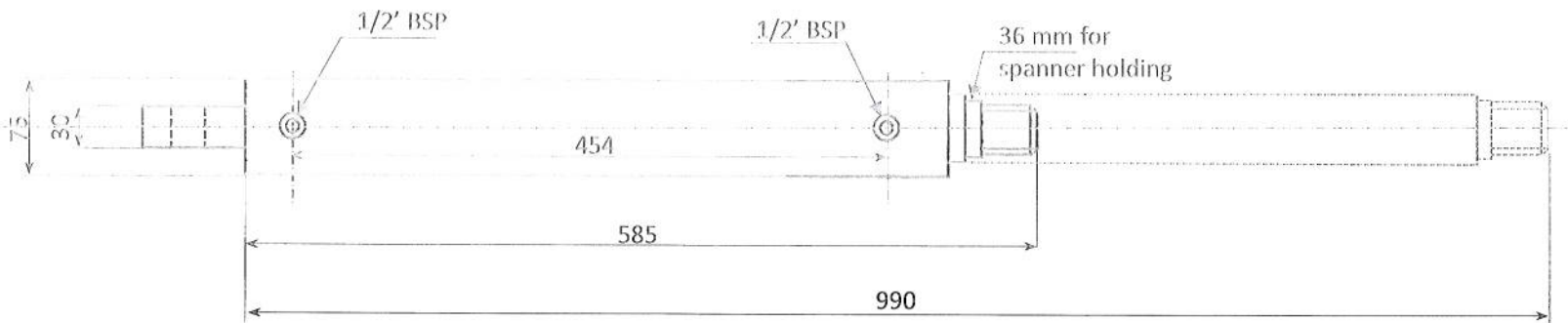
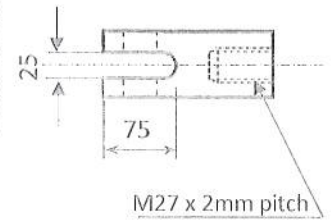
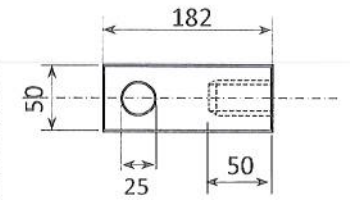

REWINDER ROLL EJECTOR HYDRAULIC CYLINDER



SL NO : 04

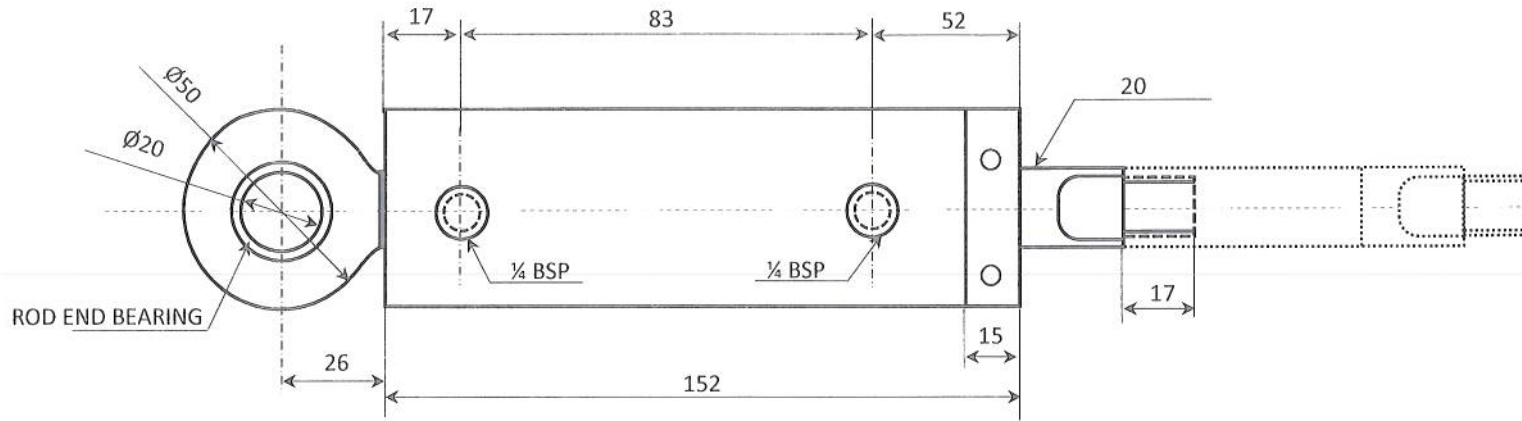

PISTON ROD END CLEVIS

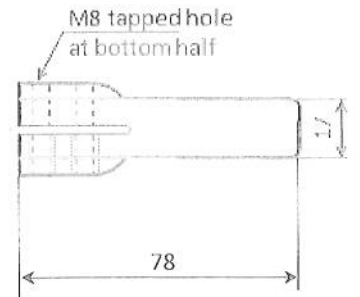
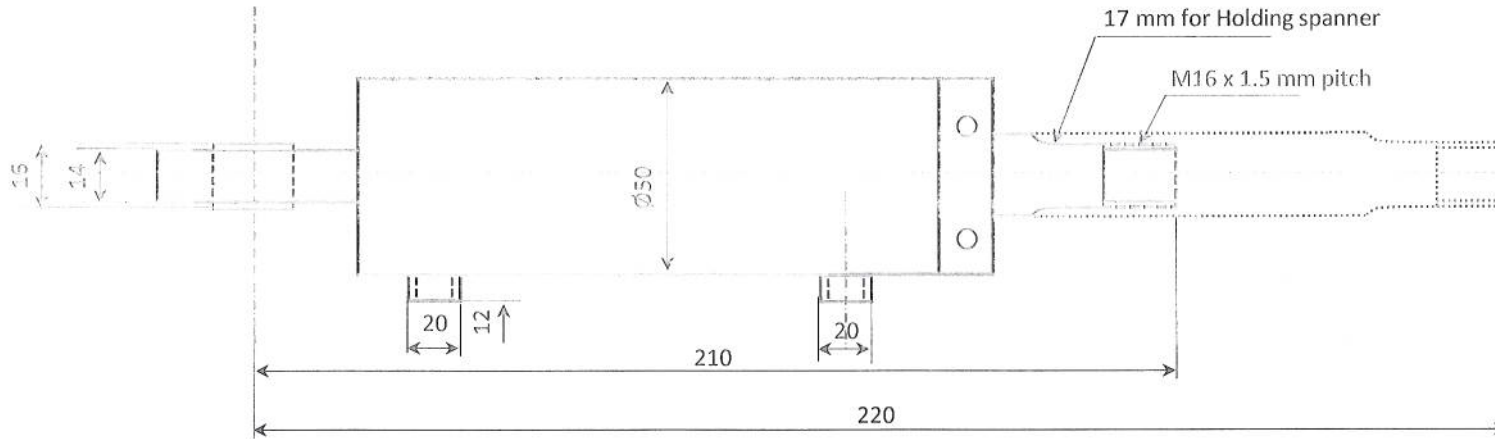
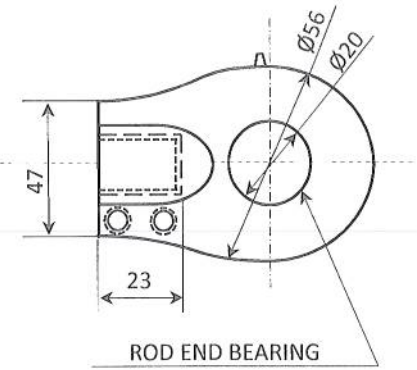

REWINDER CROSS CUTTER HYD CYLINDER



Handwritten signature